

General Description

Series PRM reducing valves are used to regulate pressure, in one area of a circuit, below normal system pressure. This style valve is well suited to perform this function as it mounts directly below the directional control valve.

Operation

These are "normally open" valves that allow fluid to pass through the controlled port during typical operation. When downstream pressure rises above the value set by an adjustable spring force, the control pilot opens and allows the main spool to move from a full open position. The main spool modulates to maintain the desired "reduced pressure" downstream of the valve. The PRM3 also has a relieving mode.

Features

- PRM sandwich style pressure reducing valves can be used to reduce pressure on the 'P' port, the 'A' port, or the 'B' port.
- Three pressure adjustment options are available: slotted screw, knob and locking knob. (PRM6 only)
- Valve bodies are manufactured from steel which provide extra strength and durability for longer life. Internal hardened steel components also provide longer life.

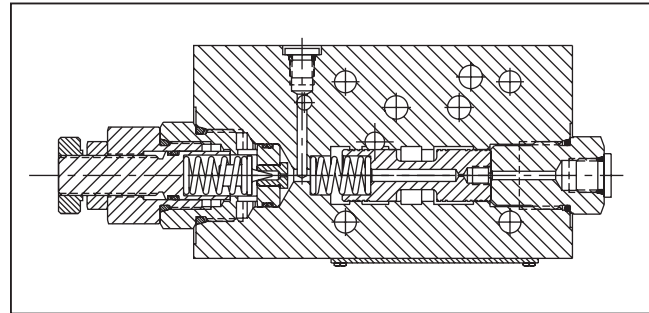
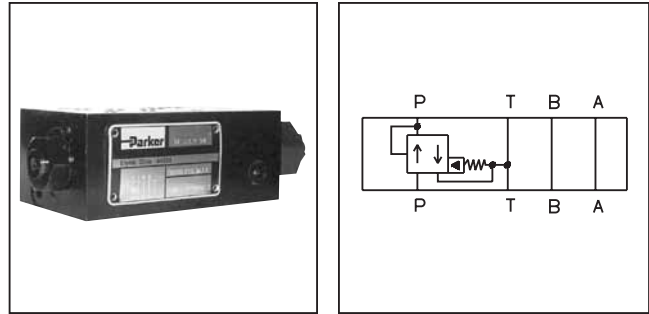

B

Specifications

	PRM3	PRM6		PRM3/PRM6										
Mounting Pattern	NFPA D05, CETOP 5, NG 10	NFPA D08, CETOP 8, NG 25	Filtration	ISO 4406 (1999); 18/16/13 (meet NAS 1638:7)										
Minimum Pressure	10 Bar (150 PSI) with rated flow, 150 SSU oil, and fluid temperature of 38°C (100°F). ¹		Venting	Connecting the vent port to tank allows the reducing valve to divert flow at minimum pressure.										
Maximum Pressure	345 Bar (5000 PSI)	345 Bar (5000 PSI)	Remote Control	Remote control valve connected to the vent port can be used to control the pressure. ²										
Min. Flow	3.78 LPM (1 GPM)	3.78 LPM (1 GPM)	Drain Line	Drain line from pilot valve is internally connected to the tank port. Tank line pressure is thus added to the valve setting. ³										
Maximum Flow	64 LPM (17 GPM)	189 LPM (50 GPM)												
Pressure Range	<table border="1"> <thead> <tr> <th>Code</th> <th>Pressure Range</th> </tr> </thead> <tbody> <tr> <td>07</td> <td>10 to 70 Bar (150 - 1000 PSI)</td> </tr> <tr> <td>17</td> <td>10 to 175 Bar (150 - 2500 PSI)</td> </tr> <tr> <td>25</td> <td>10 to 250 Bar (150 - 3500 PSI)</td> </tr> <tr> <td>35</td> <td>10 to 350 Bar (150 - 5000 PSI)</td> </tr> </tbody> </table>	Code	Pressure Range	07	10 to 70 Bar (150 - 1000 PSI)	17	10 to 175 Bar (150 - 2500 PSI)	25	10 to 250 Bar (150 - 3500 PSI)	35	10 to 350 Bar (150 - 5000 PSI)			
Code	Pressure Range													
07	10 to 70 Bar (150 - 1000 PSI)													
17	10 to 175 Bar (150 - 2500 PSI)													
25	10 to 250 Bar (150 - 3500 PSI)													
35	10 to 350 Bar (150 - 5000 PSI)													

¹ Change in flow, temperature or fluid (SSU) rating will affect valve minimum pressure.

² Set main valve pressure 10 Bar (150 PSI) higher than remote pilot.

³ It is important that the drain line connection be taken into consideration when determining the minimum valve setting.

B

PRM

Pressure Reducing Valve

Size

Port Reduction

Pressure Range

Adjustment

Seal

Gauge Port

Drain

Design Series

NOTE:
 Not required when ordering.

Code	Description
3	NFPA D05 Subplate Mounting
6	NFPA D08 Subplate Mounting

Code	Description	Available Models	
		PRM3	PRM6
PP	P Port Only	✓	
AA	A Port Only	✓	
BB	B Port Only	✓	✓
PA	P Port Reduced/Convertible to A Port Reduced		✓
AP	A Port Reduced/Convertible to P Port Reduced		✓

Code	Description
07	10 to 70 Bar (150 to 1000 PSI)
17	10 to 175 Bar (150 to 2500 PSI)
25	10 to 250 Bar (150 to 3500 PSI)
35	10 to 345 Bar (150 to 5000 PSI)

Code	Type
N	Nitrile
V	Fluorocarbon

Code	Type
K	Knob
L*	Locking Knob
S	Screw Adj.

* PRM6 only.

Code	Type
Omit*	SAE
S†	SAE
N†	NPT
M†	Metric
G	1/4 BSPP

* PRM6 only.
 † PRM3 only.

Code	Type
Omit	Internal
Y	External

Unit Weight:
 PRM3 3.0 kg (6.6 lbs.)
 PRM6 5.6 kg (12.5 lbs.)

Bold: Designates Tier I products and options.
Non-Bold: Designates Tier II products and options.
These products will have longer lead times.

Bolt Kits

Size "3"				Size "6"			
No. of Sandwich	Sandwich & Valve Combination	D3W-30 D3DW & D31*W*	Bolt Length mm (in)	No. of Sandwich	Sandwich & Valve Combination	Bolt Kit	Bolt Length mm (in)
1	Sandwich & D3	BK141	88.9 (3.50)	1	Sandwich & D6	BK121	133.4 (5.25)
2	Sandwich & D3	BK142	139.7 (5.50)	2	Sandwich & D6	BK122	203.2 (8.00)
3	Sandwich & D3	BK143	190.5 (7.50)	3	Sandwich & D6	BK123	273.1 (10.75)
				4	Sandwich & D6	BK124	342.9 (13.5)

* D31VW with internal pilot and internal drain only.

Bolt Kits must be ordered separately.

Schematics

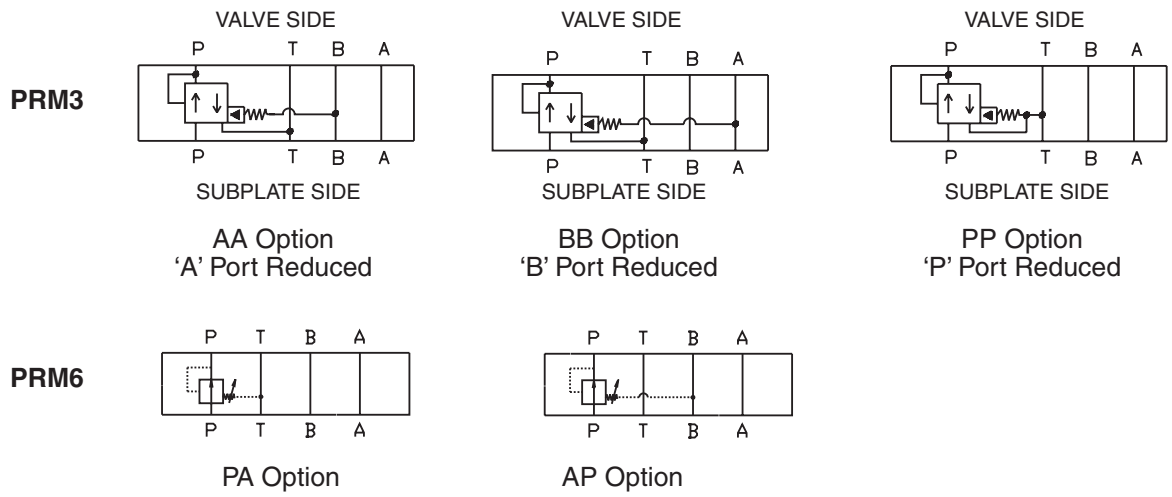

Performance Curves

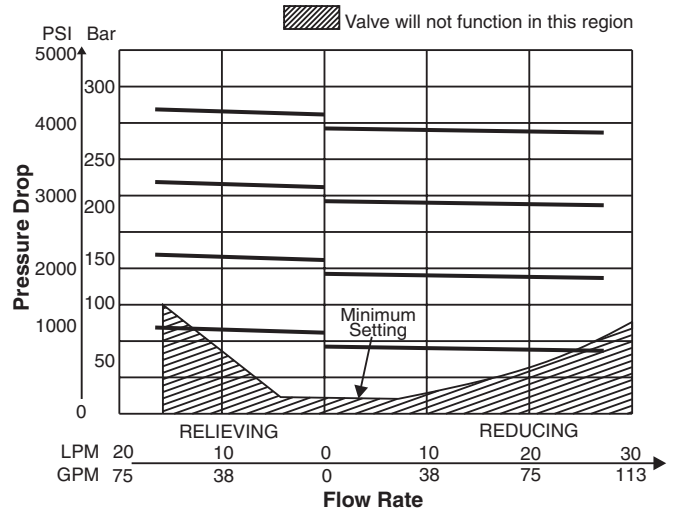
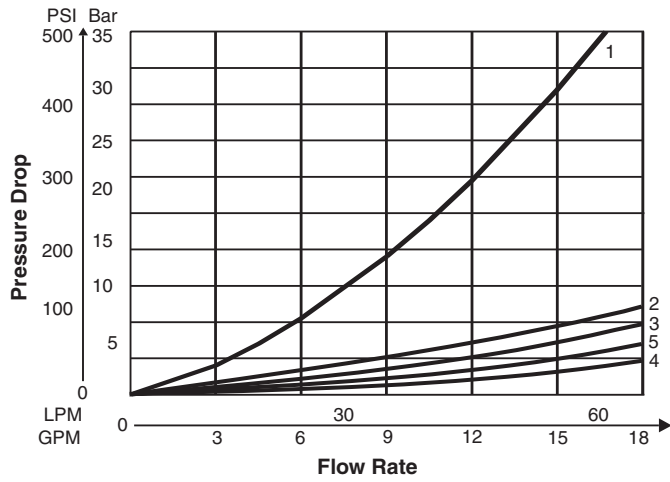

Mode	Flow Path			
	P → P	A → A	B → B	T → T
PP	1	2	3	4
AA	1	2	3	5
BB	1	2	3	5

Viscosity Correction Factor							
Viscosity (SSU)	75	150	200	250	300	350	400
% of ΔP (approx.)	93	111	119	126	132	137	141
Curves were generated using 100 SSU hydraulic oil. For any other viscosity, pressure drop will change per chart.							

NOTE: Lowest pressure setting dependent upon system resistance.

PRM3AA

Inch equivalents for millimeter dimensions are shown in (**)

B

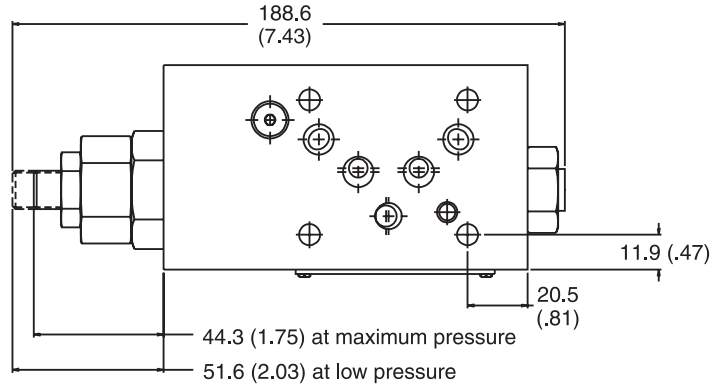

Top View

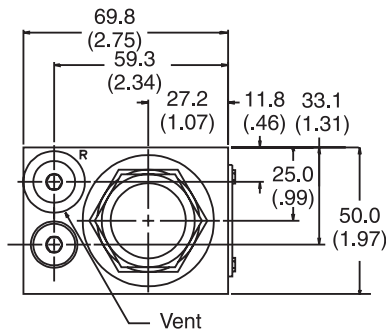

End View

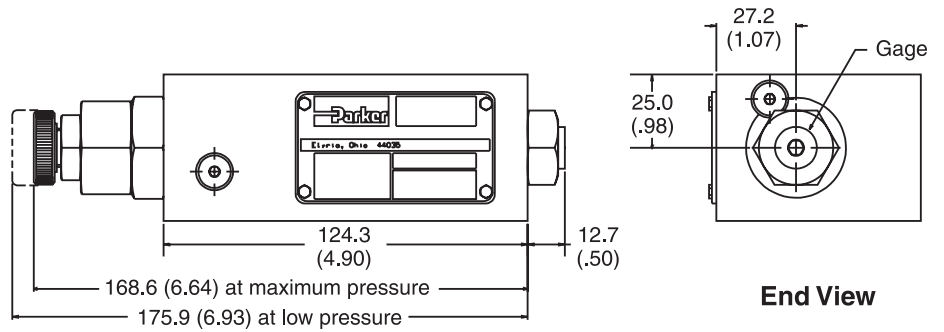

Face View

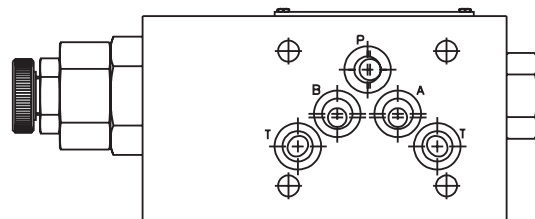

Bottom View



PRM3BB

Inch equivalents for millimeter dimensions are shown in (**)

B

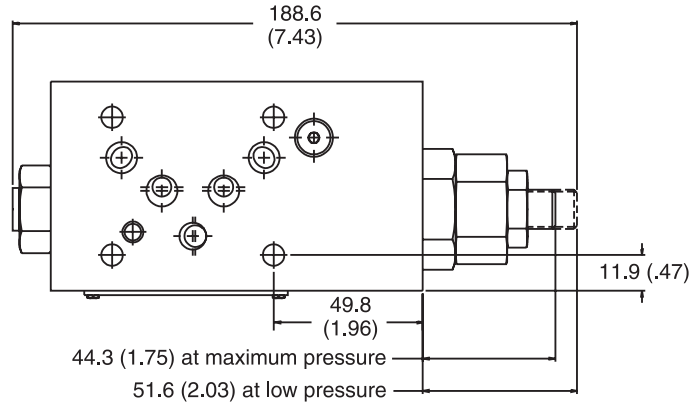

Top View

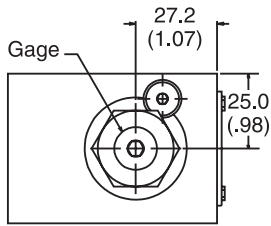

End View

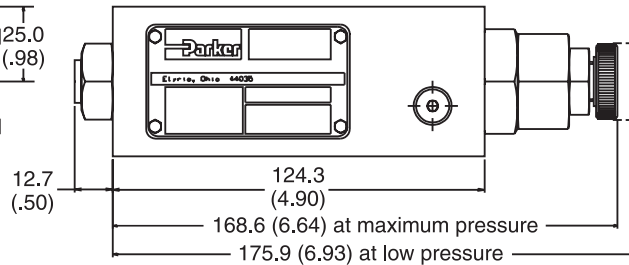

Face View

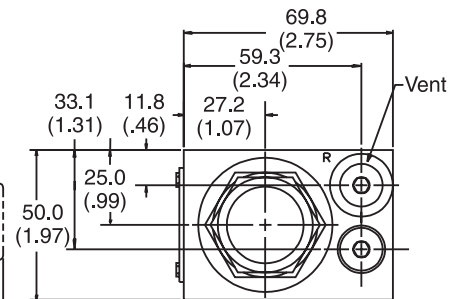

End View

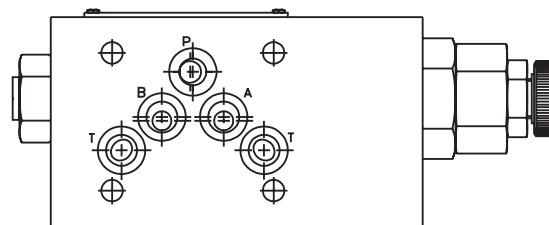

Bottom View



PRM3PP

Inch equivalents for millimeter dimensions are shown in (**)

B

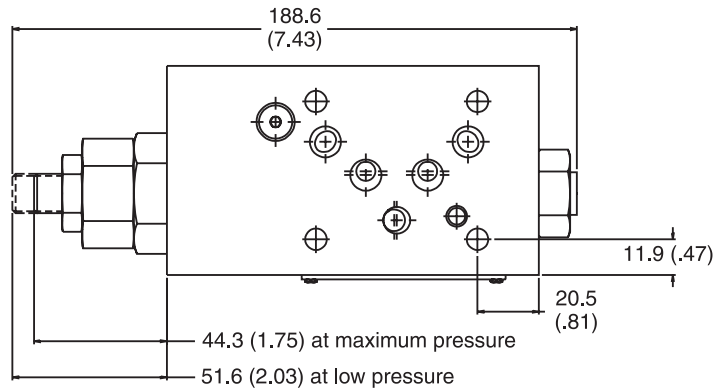

Top View

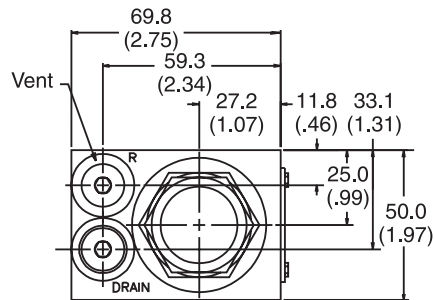

End View

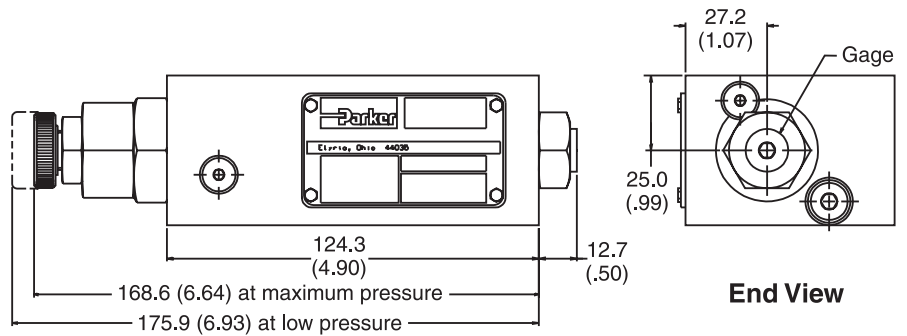

Face View

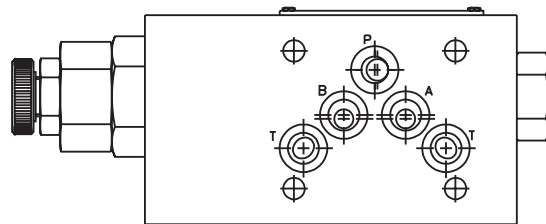

Bottom View



Inch equivalents for millimeter dimensions are shown in (**)

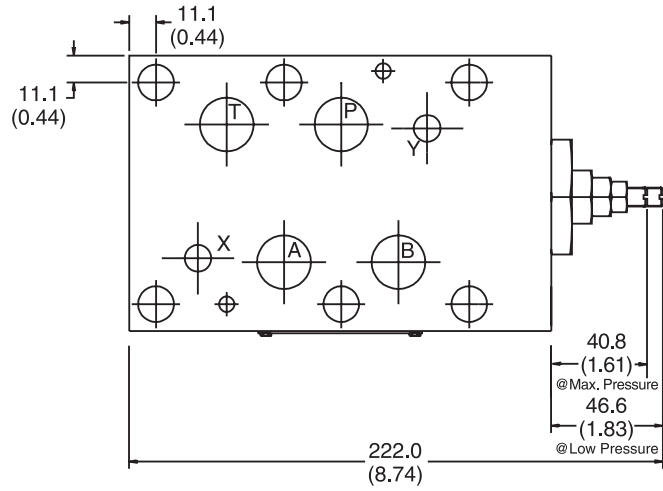

Top View

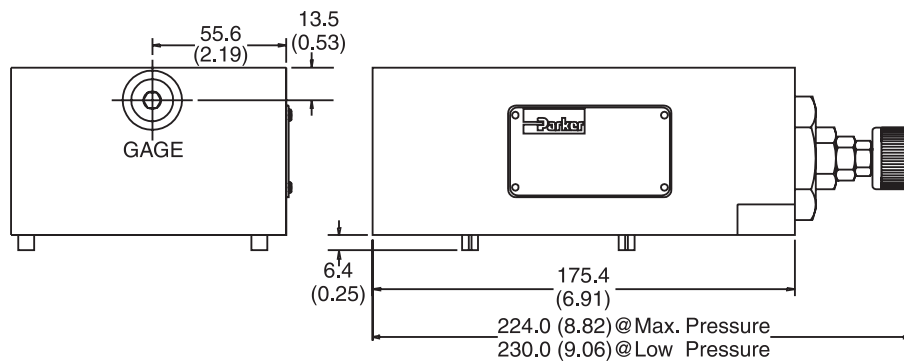

Face View

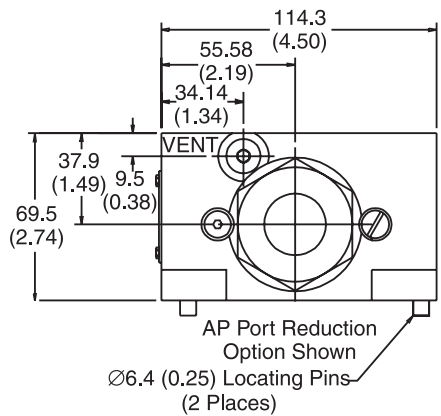

End View

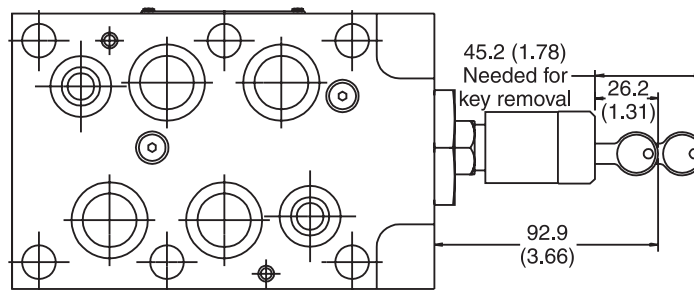

Bottom View

B

