

YARWAY PROCESS THERMODYNAMIC STEAM TRAPS

SERIES 40/40D AND C250/260

Designed for a variety of high pressure and high capacity applications found in utility, industrial and marine service

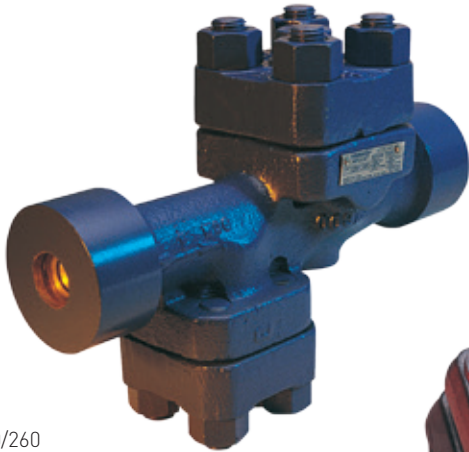

C250/260



40

FEATURES

- Excellent air handling
- Fail-open design
- In-line repairable
- Compact and lightweight
- Long-life design
- Stainless internals
- Unaffected by corrosive condensate, freezing, and water hammer
- Performance tested per ASME PTC-39.1

GENERAL APPLICATION

Designed for high pressure and large condensate load applications found in utility, industrial and marine service.

TECHNICAL DATA

Technology:	Thermodynamic piston and lever
Size:	NPS ½, ¾, 1, 1½, 2, 3 DN 15, 20, 25, 40, 50, 80
Temperature:	Max. design 750°F [400°C]
Pressure rating:	2 to 1500 psig [0.14 to 103 bar]
Capacity:	Up to 80,000 lb/hr [36,000 kg/hr]
Connections:	Socket weld, Threaded, Flanged
Materials:	Chrome moly

YARWAY PROCESS THERMODYNAMIC STEAM TRAPS

GUIDELINES FOR TYPICAL PROCESS APPLICATIONS

Depending on the application, a process steam trap may need to handle heavy startup loads, often followed by smaller running loads.

The trap's function is to drain the process equipment and thus ensure that effective heat transfer is achieved (through latent heat).

A few guidelines for optimum results include:

- Provide an adequate size process connection from equipment.
- Locate trap below the equipment (water runs downhill).
- Use good piping practice to ensure that clean condensate is presented to the trap.
- Include air vents and vacuum breakers as necessary for effective equipment operation.

PROFILE OF A PROCESS APPLICATION - GRAVITY DRAINAGE, SHELL AND TUBE HEAT EXCHANGER

Tubes, coils or jackets are used with heat exchangers, tanks or vats for heating liquids in either batch or continuous operation, typical of shell and tube heaters. Equipment is generally protected from the weather and typically features a single coil.

Heavy startup loads, followed by smaller running loads are to be expected, but without the extreme swings of weather-exposed equipment.

Adequate air venting is most important as the equipment is often run on daily or weekly schedules. Tendency is for total shutdown of equipment following completion of run or batch. Air in a heating system significantly reduces its efficiency. Air is a very poor conductor of heat and air filming on pipes and heat exchanger tubes reduces the heat

transfer rate through their metal walls.

Also, steam mixed with air contains fewer BTUs at a given pressure than steam alone. It is the function of a steam trap to aid in venting air from a steam system, but auxiliary thermostatic air vents are often required. Open to cooler air and closed to hotter steam they greatly speed up the air purging process. When frequent startups and shutdowns are the rule, rapid air purging is a significant factor. Yarway lever style thermodynamic traps are often favored for their excellent air handling characteristics on startup.

PROFILE OF A PROCESS APPLICATION - SYPHON/LIFT DRAINAGE ROTARY DRIER (USING LEVER TRAPS)

In this application, continuous drying of materials is being performed by exposure to the heated surfaces of rotating cylinders or drums. Commonly used in the manufacture of felt, rubber, textiles, paper and other sheet or fibrous materials, including foods and slurries of chemicals.

Higher start-up loads and moderate running loads are typical. When several dryers are in series, the first will have the highest load while those toward the end have progressively smaller loads. Each dryer should be trapped individually to prevent flooding. Syphon drainage is standard practice. CAUTION! Condensate moving up the syphon from the outer rim to the center of the drum is subject to reheating and flashing. Flashed condensate can break the siphon (steam binding). Therefore, steam traps must have hot discharge and fast response with the ability to handle flash steam by means of a small bleed passage. Air venting capability is an important requirement during start-up when drums or cylinders contain large amounts of air.

Shell and tube heater

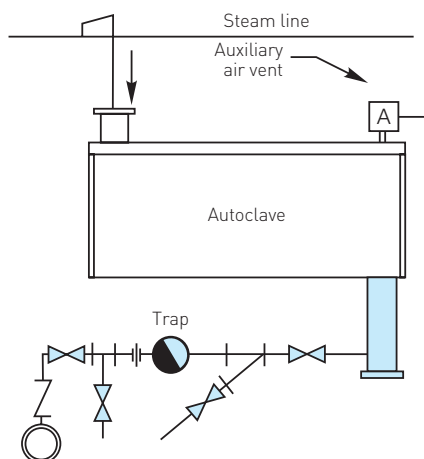

Rotating cylinder dryer (syphon drained)

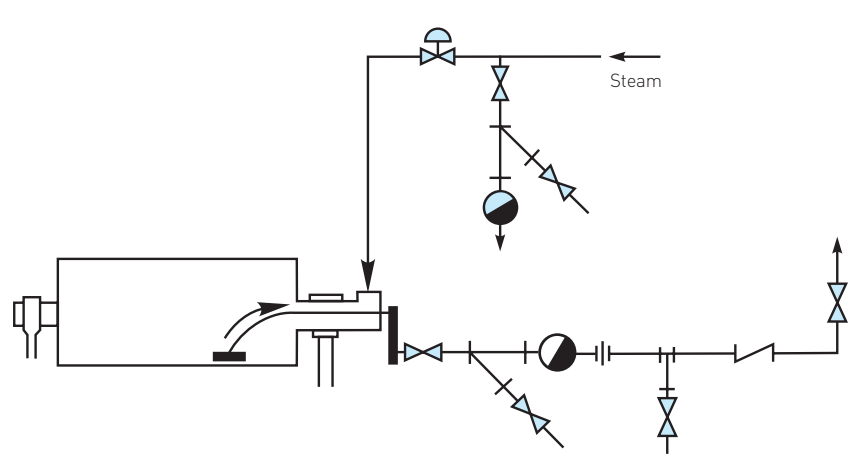

YARWAY PROCESS THERMODYNAMIC STEAM TRAPS

THE RIGHT TRAP FOR THE RIGHT APPLICATION

Why choose a thermodynamic steam trap?

Thermodynamic traps are phase detectors in that they can discriminate between condensate and steam. The working principle is simple and, with only one moving part, these devices are small and rugged. There are three basic types of thermodynamic traps which differ from one another by the configuration of the valve they use to open and close a port. Each is well-adapted to a particular set of service conditions. The main thermodynamic feature that is desirable in process applications is the hot-running design and responsiveness to load changes. Thermodynamic traps also handle air very well, which is essential to an efficient heat transfer rate. This requires an understanding that steam mixed with air contains fewer BTUs at a given pressure than pure steam.

Variable orifice traps

These traps are designed for a variety of high pressure applications found in utility, industrial and marine service. Typical applications include: fuel oil heaters, air heaters, reboilers, soot blower drains, steam separators, and shell and tube heat exchangers.

The small lightweight design and broad range of operating pressures are among the many advantages when compared to mechanical traps of the same pressure rating. Yarway variable orifice traps offer the following advantages:

- Moderate capacity
- Excellent air handling
- Designed to fail open
- Designed for superheat
- In-line renewable
- Long life materials
- Broad range of pressure class
- Integral screen
- Compact and lightweight
- Factory set and assembled internals
- Optional blow-off valve connection
- End connections - socketwelding standard
- Seaworthy - shock and vibration tested

How it works - variable orifice design

Variable orifice traps differentiate between the energy in cool condensate and flashing condensate as well as gases. Cool condensate opens the valve because the pressure in the chamber above the valve is low. The cool condensate readily drains through the control orifice from the chamber. Hot flashing condensate chokes the flow in the orifice and raises the chamber pressure. The increased chamber pressure closes the valve. When the valve is closed, a small amount of condensate continuously drains through the control orifice, making the trap responsive to changes in condensate load.

Lever style traps

These traps are especially suited for outdoor service and freezing environment, and where the equipment has siphon or lift drainage. The built-in control orifice prevents steam binding as well as promoting excellent air handling. Among the typical applications are air blast heating coils, batch stills, autoclaves, reboilers, rotating cylinder dryers, and shell and tube heaters. All Yarway lever valve traps deliver consistent features such as:

- High capacity - replaces traps of larger physical size
- Excellent air handling
- Fail-safe in the open position to help maintain production
- Lever valve is only moving part
- Stainless steel internals
- Unaffected by corrosive condensate, freezing, and water hammer
- In-line maintenance - factory matched repair kit installed in minutes
- Full range operation - without adjustment
- High temperature discharge

How it works - lever style design

On startup, air is handled through a control orifice. Only cool condensate or a mixture of condensate and air, will open the valve lever. As steam temperature condensate reaches the trap, flashing begins in the outlet orifice, building up pressure in the chamber above the lever. The lever closes as the chamber pressure increases. A small "control flow" permits quick response to inlet conditions. A slight drop in condensate temperature, for instance, reduces the chamber pressure, quickly opening the lever. Lever traps are designed for applications having large condensate loads and where rapid discharge of condensate is a requirement.

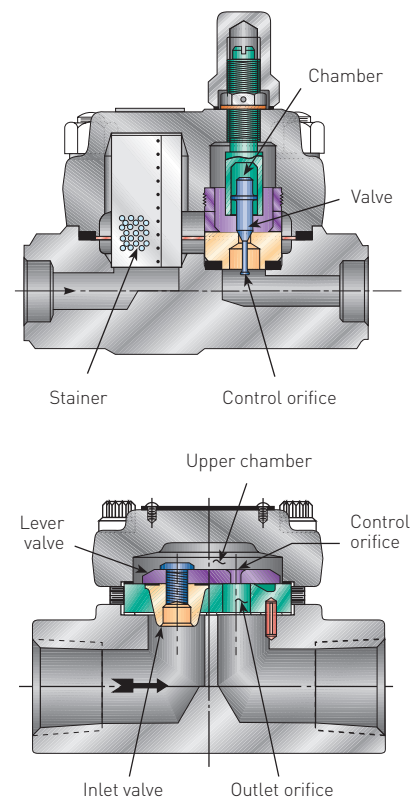

YARWAY PROCESS THERMODYNAMIC STEAM TRAPS

SERIES C-250 AND C-260 HIGH PRESSURE TRAPS (VARIABLE ORIFICE)

The Yarway high pressure integral strainer trap is designed with Quick Change Trim (QCT) using the proven variable orifice (piston) internals. These traps are designed for a variety of high pressure applications found in utility, industrial and marine service. Typical applications include: fuel oil heaters, air heaters, reboilers, soot blower drains, steam separators, and shell and tube heat exchangers.

The small lightweight design and broad range of operating pressures are among the many advantages when compared to mechanical traps of the same pressure rating. In addition, the QCT design is renewable in-line with factory set and assembled internals.

Back pressure ratings

Back pressure to 25% as factory set; (to 55% with removal of split washer, based on absolute pressure, C-250 only).

How to specify and order

Typical specification

The trap shall be Piston Valve, Quick Change Trim, Integral Strainer, Impulse® Trap and shall require neither bucket, bellows nor bimetallic element for operation - (option ½" socketweld blow-off connection).

Ordering

1. Designate size of end connections.
2. Designate figure number.
3. Designate trap internals (capacities curve and selector guide).
4. Designate "R" for commercial.
Example: 1½" C-250ESWR.

Applicable codes and standards

Pressure ratings per ASME/FCI-69-1.
Performance testing per ASME PTC-39.1, ISO 7841 and 7842, FCI 69.1 and 85.1.
End connections per ASME B16.11.

How to interpret the curves

For optimum service life limit the C-250 to 600 psi [41bar] operation and the C-260 to 1500 psi [103 bar] operation. Traps will operate above recommended pressure (C-250 up to 1000 psi [69 bar] C-260 up to 3000 psi [206 bar]). However, the service life may be reduced.



CONDENSATE CAPACITY NEAR STEAM TEMPERATURE (FOR STEAM TRAP SIZING)

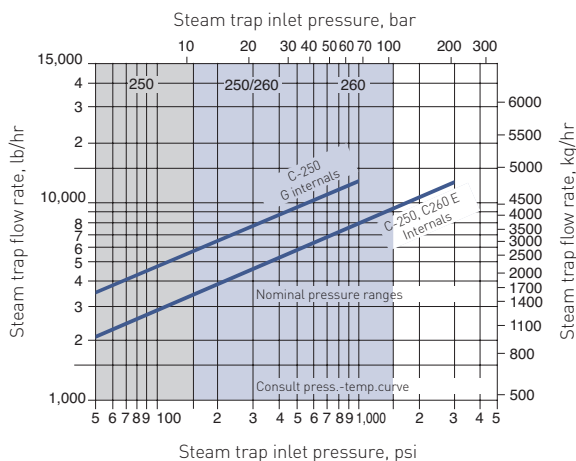

PRESSURE/TEMPERATURE RATINGS

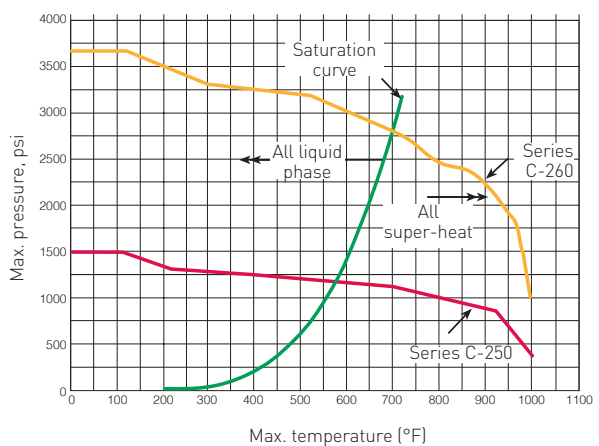

YARWAY PROCESS THERMODYNAMIC STEAM TRAPS

SERIES C-250/C-260

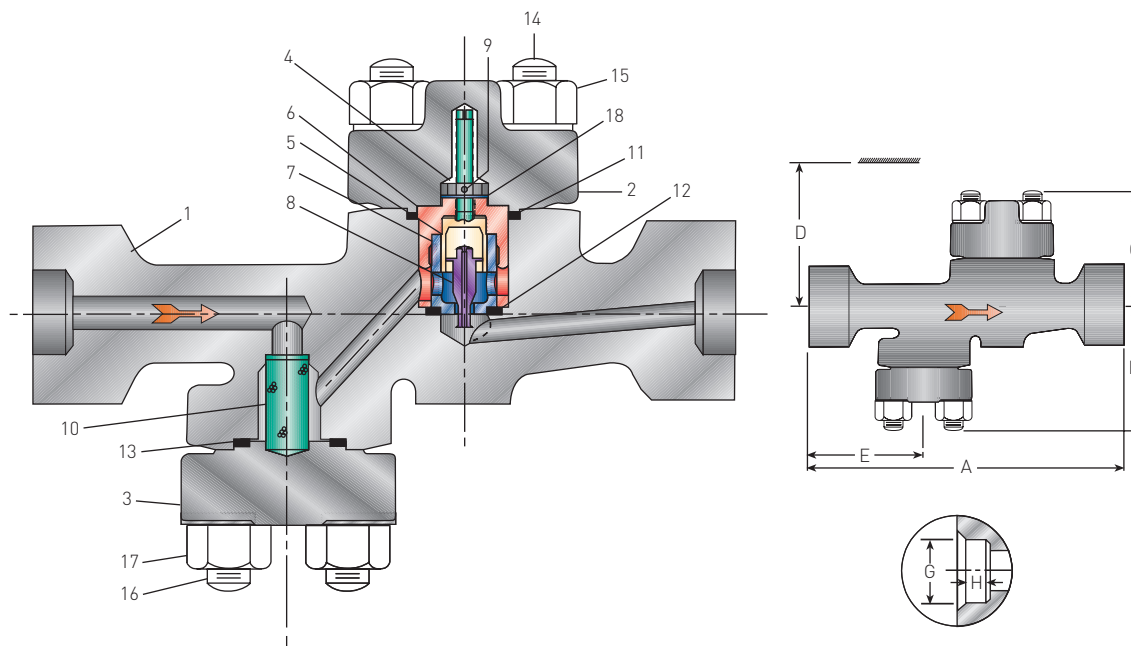

MATERIALS AND SPECIFICATIONS

Item	Part	Material
1	Body	Cast chrome moly ASTM A-217 Gr. WC6 .15 Max C (body)
2	Trap bonnet	Cast chrome moly ASTM A-217 Gr. WC6 .15 Max C (body)
3	Strainer bonnet	Cast chrome moly ASTM A-217 Gr. WC6 .15 Max C (body)
4 ⁱ	Lock nut	Stainless steel AISI Series 400
5 ⁱ	Control cylinder	Stainless steel AISI Series 400
6 ⁱ	Control cylinder adapter	Stainless steel AISI Series 400
7 ⁱ	Seat	Steel AISI Series 400 heat treated
8 ⁱ	Valve piece	Stainless steel AISI Series 400 heat treated
9 ⁱ	Lock pin	Brass [C-250] Monel® [C-260]
10 ⁱ	Screen	Stainless steel AISI Series 300 (0.020" perf.)
11 ⁱ	Bonnet gasket (trap)	Inconel® spiral wound non-asbestos
12 ⁱ	Seat gasket	Inconel® spiral wound non-asbestos
13	Bonnet gasket (strainer)	Inconel® spiral wound non-asbestos
14	Stud (trap bonnet)	Steel ASTM A-193 B-16
15	Nut (trap bonnet)	Steel ASTM A-194 Gr. 7
16	Stud (strainer bonnet)	Steel ASTM A-193 B-16
17	Nut (strainer bonnet)	Steel ASTM A-194 Gr. 7
18 ⁱ	Split washer	Brass [C-250 only]

NOTES:

- Supplied in a renewal kit

DIMENSIONS/WEIGHTS

Series	Size	Dimensions, in. (mm)						Weight	
		A	B	C	D	E	G	H	lb. (kg)
C-250	1 [25]	11½ [292]	5 [127]	5 [127]	7½ [190]	4⅞ [105]	1.335 [34]	½ [15]	39 [18]
C-250	1½ [40]	11½ [292]	5 [127]	5 [127]	7½ [190]	4⅞ [105]	1.915 [48]	½ [15]	39 [18]
C-260	1 [25]	14¾ [365]	5½ [140]	5⅝ [130]	7½ [190]	5¼ [133]	1.335 [34]	½ [15]	62 [28]
C-260	1½ [40]	14¾ [365]	5½ [140]	5⅝ [130]	7½ [190]	5¼ [133]	1.915 [48]	½ [15]	62 [28]
C-260	2 [50]	14¾ [365]	5½ [140]	5⅝ [130]	7½ [190]	5¼ [133]	2.406 [61]	⅝ [16]	62 [28]

YARWAY PROCESS THERMODYNAMIC STEAM TRAPS

SERIES 40/40D LEVER VALVE TRAPS

The Series 40/40D is designed for use in industrial process applications for pressures up to 600 psi [41 bar] and condensate loads to 80,000 lb/hr [36,000 kg/hr].

Applicable codes and standards

Pressure ratings per ASME/FCI-69-1. Performance testing per ASME PTC-39.1. End connections per ASME B1.20.1. for threaded ends, per ASME B16.11 for socketwelding ends, and per ASME B16.5 for flanged ends.

How to size

Required steam trap flow rate = maximum expected condensate load (lb/hr) x Safety load factor. A safety load factor of 2-4 is usually recommended. Then select a trap from the condensate capacity chart. Do not size based on end connection.

How to specify, order and install

Typical specification

The trap shall be thermodynamic lever valve type requiring neither bucket, float, bellows, nor bimetallic element, with stainless steel internals and chrome moly body and bonnet.

Ordering

Specify trap size and series. Threaded end connections are standard; socketwelding or flanged ends are available. Repair kits are supplied as sets of matched parts (lever valve, seat, gaskets). Order by size and series.

Installation

Install trap bonnet up in a horizontal position. Pitch lines to and from trap for gravity drainage.



CONDENSATE CAPACITY (FOR STEAM TRAP SIZING)

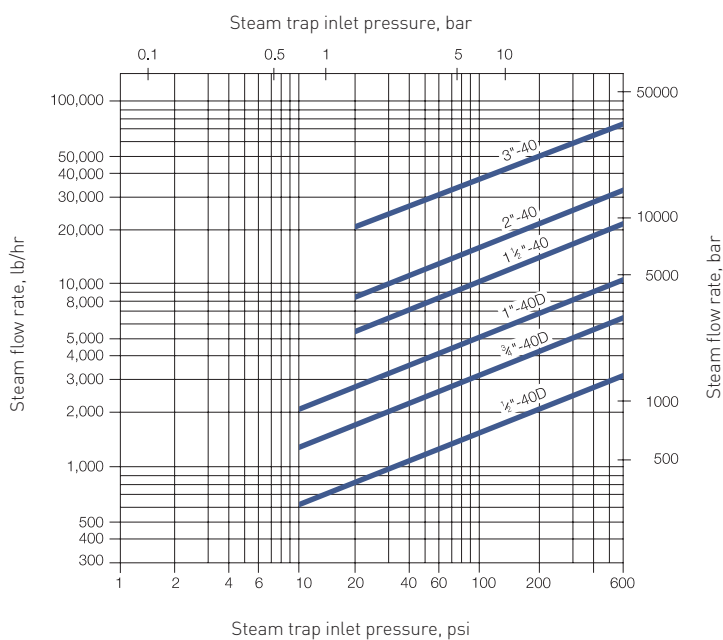

RATINGS (DESIGN - FCI CLASS 600)

Series	Size in (DN)	Pressure range psi (bar)	Max. temperature °F (°C)
40D	1/2, 3/4 (15, 20)	2 - 600 (0.14 - 42)	750 (400)
40D	1 (25)	5 - 600 (0.34 - 42)	750 (400)
40	1-1/2, 2, 3 (40, 50, 80)	20 - 600 (1.38 - 42)	750 (400)

NOTE:

- Operates against back pressure at trap outlet up to 40% of pressure at trap inlet. Based on absolute pressure when trap is discharging.

YARWAY PROCESS THERMODYNAMIC STEAM TRAPS

SERIES 40D / SERIES 40

DIMENSIONS/WEIGHTS SERIES 40D

Size* (DN)	Dimensions, in. (mm)					Weight lb. (kg)
	A	B	C	D	E	
1/2 (15)	3-1/8 (79)	2 3/16 (56)	1 1/16 (40)	2 (51)	1 3/16** (48)	2 (0.91)
3/4 (20)	4 (102)	2 13/16 (71)	2 1/16 (52)	2 5/8 (67)	1 1/2** (38)	3 3/4 (1.71)
1 (25)	5 (127)	3 7/16 (90)	2 11/16 (68)	3 1/2 (89)	1 3/4** (44)	8 (3.6)

* NPT Standard. Socketwelding or flanged end connections also available. Consult Yarway.

DIMENSIONS/WEIGHTS SERIES 40

Size* (DN)	Dimensions, in. (mm)					Weight lb. (kg)
	A	B	C	D	E	
1-1/2 (40)	7 (178)	4 7/8 (124)	3 9/16 (90)	4 3/8 (111)	Ø 2 5/8 (67)	14 (6.4)
2 (50)	7 5/8 (194)	5 7/8 (149)	4 5/16 (110)	5 1/8 (130)	Ø 3 1/8 (79)	22 (10.0)
3 (80)	10 5/8 (270)	8 3/16 (213)	6 1/16 (154)	7 3/8 (187)	Ø 4 5/8 (117)	65 (29.5)

* NPT Standard. Socketwelding or flanged end connections also available. Consult Yarway.

MATERIALS AND SPECIFICATIONS SERIES 40D

Item	Part	Material
1	Body	Forged Cr-Moly steel ASTM A182 F22
2 ¹	Bonnet	Forged Cr-Moly steel ASTM A182 F11
3 ¹	Lever valve	Stainless steel Type 410, heat treated
4 ¹	Seat	Stainless steel Type 410, heat treated
5 ¹	Inlet valve	Stainless steel Type 410, heat treated
6 ¹	Bonnet gasket	Monel®
7 ¹	Body gasket	Monel®
8 ¹	Outlet port gasket (1" size only)	Monel®
9	Cap screw	Alloy steel heat treated
10	Nameplate	Stainless steel
11	Drive screw	Stainless steel
12 ¹	Inlet valve rivet	Stainless steel Type 410
13	Spring pin	Stainless steel Type 303

NOTES:

1. Supplied in a renewal kit

MATERIALS AND SPECIFICATIONS SERIES 40D

Item	Part	Material
1	Body	Cast Cr-Moly steel ASTM A182-F22 (size NPS 1 1/2 and 2) A217-WC9 (size 3")
2	Bonnet	Cast Cr-Moly steel ASTM A182-F11 (size 1 1/2 and 2) A217-WC6 (size 3")
3 ¹	Lever valve	Stainless steel Type 410
4 ¹	Seat	Stainless steel Type 410, heat treated
5 ¹	Inlet valve	Stainless steel Type 410, heat treated
6 ¹	Outlet valve	Stainless steel Type 410, heat treated
7 ¹	Body gasket	Stainless steel spiral wound (non-asbestos)
8 ¹	Bonnet gasket	Stainless steel spiral wound (non-asbestos)
9 ¹	Outlet port gasket	Stainless steel spiral wound (non-asbestos)
10	Outlet port bushing	Stainless steel Type 304
11	Cap screw	Alloy steel heat treated
12	Drive screw	Stainless steel
13	Nameplate	Stainless steel

NOTES:

1. Supplied in a renewal kit

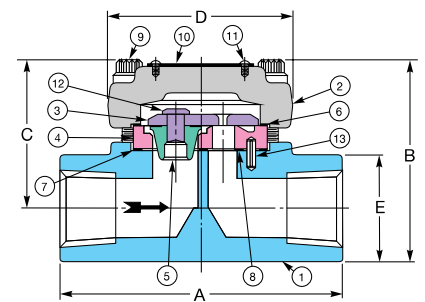

SERIES 40D

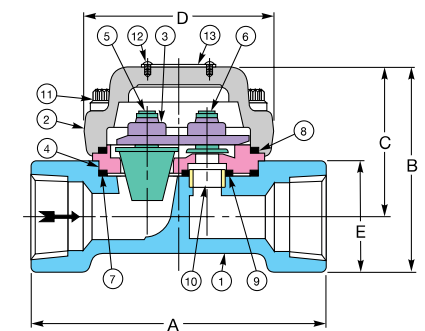

SERIES 40



PENTAIR VALVES & CONTROLS

www.pentair.com/valves

All Pentair trademarks and logos are owned by Pentair plc. All other brand or product names are trademarks or registered marks of their respective owners. Because we are continuously improving our products and services, Pentair reserves the right to change product designs and specifications without notice. Pentair is an equal opportunity employer. © 2015 Pentair plc. All rights reserved.