

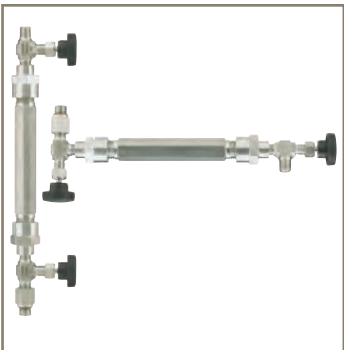

aerospace
climate control
electromechanical
filtration
fluid & gas handling
hydraulics
pneumatics
process control
sealing & shielding



High Pressure Compressed Air and Gas Filters

J-Series High Efficiency Filters / CNG and Alternative Fuel Filters

Bulletin 1300-220/USA Rev A



ENGINEERING YOUR SUCCESS.

Finite J-Series High Pressure Filters

Why do high pressure systems need filtration?

High pressure compressors are used in a variety of applications. Many owners, operators and designers of high pressure compressed air or gas systems rely on Parker's Finite Filter Operation for high efficiency filters. End users of high pressure compressed air, such as scuba divers and fire rescue workers, depend on high quality breathable air.

Throughout the stages of compression many contaminants can enter into the system. Excessive amounts of liquid aerosols, primarily lube oil carryover and solid particulate contamination are common in high pressure systems. In addition, higher temperature levels are possible and may cause liquid oils to varnish. This contamination can lead to poor component performance and wear that may lead to unscheduled maintenance. Even submicronic contaminants in compressed air or gas systems can foul multistage compressors, increasing maintenance costs and impacting product quality.

Parker's Finite Filter Operation offers a variety of high pressure compressed air and gas filters. With our wide range of elements, we have a solution for every stage of compression, as well as at the point of use. Whether you are storing high pressure air or gas or using a continuous flow, count on Parker to protect your equipment from contamination. Parker Finite is the solution to ending high pressure contamination fouling.

Parker's Finite Filter Operation's J-Series Filters are designed to filter contaminants such as rust, pipe scale, compressor lube oil, and water from compressed gases. These filters are often used in high pressure compressed natural gas (CNG) systems, not only as inter-stage filters in the multi-stage compression of the gas, but also in the storage and delivery of the gas for CNG powered vehicles.



Parker's varied media choices remove up to 99.995% of both solid and liquid aerosols, and contaminants as small as 0.01 microns in size. An activated carbon media is also available which removes oil vapor. This stage of filtration is often used as the final filter before the storage of high pressure breathing air used by scuba divers, firefighters, and others who utilize portable breathing devices.

The filter housings and the replaceable elements used in this product line have an extremely robust construction, specially designed for use in system pressures up to 5,000 psig. Five housing sizes and two thread styles (NPT or SAE) are available with connections ranging from 1/4" to 2"; temperatures up to 350°F, and flows up to 26,000 SCFM at 5,000 PSIG.

- CNG, alternative fuel and breathing air filters
- Pressures to 5000 PSIG
- Spheroidal Graphite Cast Iron
- Coalescing, particulate and adsorption filter elements available

Filter Element Features

Parker Finite offers six filter media grades ensuring that we have the correct media choice for nearly any application requirement.

Available are coalescing grades with 95% to 99.995% efficiency and pleated or UNI-CAST coalescing media designs. Additionally, a bulk liquid separator, a particulate removal and oil vapor removal choices are standard offerings.

Each element uses a retention clip design that ensures the element is seated and sealed properly. This built-in, fail-safe feature will virtually eliminate any possibility of contaminant by-pass and is unique amongst high pressure filters.

Each element is composed of internal and external plated carbon steel retainers which provide the element with a 75+ PSID burst rating. Each element also features a bore seal interface with the housing, an anti-vibration shoulder, and an integrated standoff which minimizes the likelihood of any movement of the element, even during severe system pulsations.

Element standoff lengths were designed for each housing size to allow an optimal volume of liquid contaminant to be collected in the filter's quiet zone, further minimizing any chance of contaminant carryover.

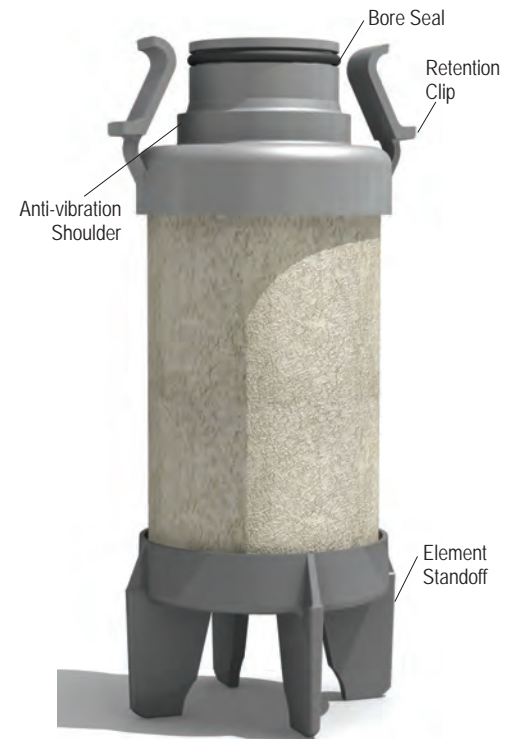

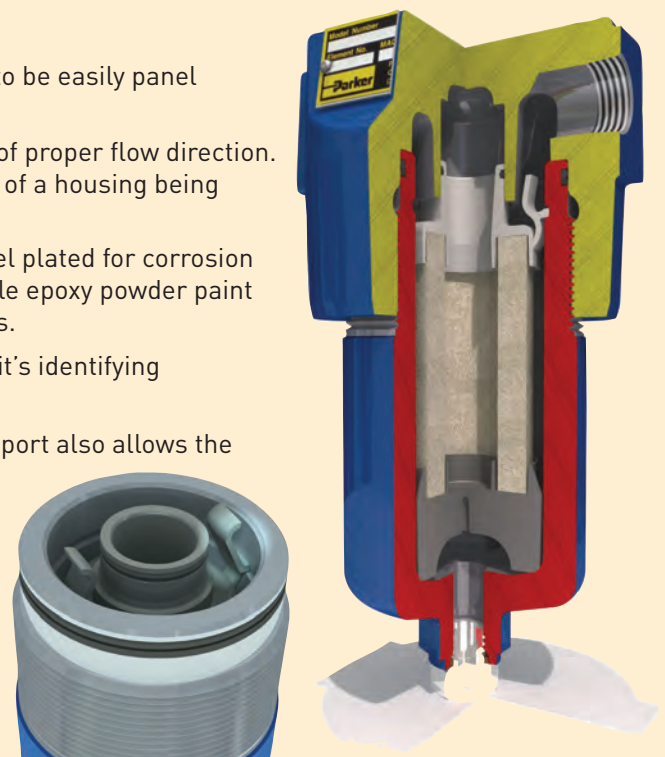

Filter Housing Features

- Robust, spheroidal graphite-cast iron offers higher mechanical strength, improved ductility, and increased shock resistance, assuring the user that this filter is built for the task at hand.
- Head to bowl bore seal ensures greater seal integrity.
- Threaded mounting holes on top of filter head allow each size to be easily panel mounted when line mounting is not an option.
- Engraved flow direction arrow in filter's head notifies the user of proper flow direction. One direction flow for all media choices reduces the possibility of a housing being installed improperly.
- The spheroidal graphite cast iron head and steel bowl are nickel plated for corrosion resistance. The completed assembly is finished with a UV stable epoxy powder paint that will allow the filter to stand-up to harsh outdoor conditions.
- An imprinted aluminum part number tag ensures that each unit's identifying information will be visible in the years ahead.
- SAE-6 steel drain plug with positive o-ring seal installed. This port also allows the easy installation of Finite's JDK5000H or JDK5000V high pressure drain kits which allow the safe removal of liquid contamination at system pressures.
- Bowls are designed to be easily tightened or loosened with a standard socket wrench.
- Bowls feature a slotted positional locator which enables the element to be positively retained, therefore having a low bowl removal clearance.



Element Types and Media Grade Options

Coalescers:		Water Separator:		Adsorber:		Particulate:	
Removes: Oil, water, liquids		Removes: Bulk liquids		Removes: Oil vapor (odor)		Removes: Solid contaminants	
Coalescing elements are specially designed for the removal of liquid contaminants from gaseous flows. These media types flow from the inside of the element to the outside. Coalesced liquid collects in the bowl where it is drained, while clean air or gas exits the housing through the outlet port. Particulate contaminants are captured and held in the media.		In this element, the gas or liquid flows from the inside of the element to the outside		Adsorption elements are used to remove vapors (hydrocarbon) that are not removed by the coalescing filter. Hydrocarbon vapors collect in the element, while clean air exits the housing through the outlet port. In this element, the air or gas flows from the inside of the element to the outside		Particulate filters in the J-Series flow from the inside of the element to the outside. Particles collect in the element, while the clean air exits through the outlet port.	
							
Type C	Type 7CP	Type WS	Type A	Type 3P			
The Finite UNI-CAST coalescing elements are made of epoxy saturated borosilicate glass microfiber and includes a polyester drain layer. (1)(2)	This pleated coalescer is made of fluorocarbon saturated borosilicate glass microfiber and includes a polyester drain layer. (1)(2)	The Finite water separator element is composed of wrapped stainless steel mesh. (1)(2)	Our Type A media is wrapped activated carbon. This element has a galvanized carbon steel inner retainer and a stainless steel perforated metal outer retaining layer. (2) * Consult factory for other media types.	This 3 micron absolute rated pleated element is made of cellulose. (1)(2)			

Notes:

- 1 Each element is retained internally and externally with galvanized carbon steel perforated metal. Not shown in some photos above.
- 2 Top and bottom end caps are made of glass filled nylon to ensure durability.

Media Grades and Specifications:

Finite media grades determine the filtration efficiency. Capture efficiencies are available up to 99.995%. Micron ratings range from 0.01 to 3 micron. The columns on the right note both the wet and dry pressure drops.

Grade	Designation	Media Type	Removes...	Coalescing Efficiency	Max Oil Carryover ppm ¹	Micron Rating (um)	Pressure Drop Media Dry (PSID)	Additional Pressure Drop Media Wet ² (PSID)
4C		Coalescing	Liquid from Gas	99.995%	0.003	0.01	1.25	3-4
7CP		Coalescing	Liquid from Gas	99.5%	0.09	0.5	0.25	0.5-0.7
10C		Coalescing	Liquid from Gas	95%	0.85	1.0	0.5	0.5
WS		Bulk Separator	Bulk Liquid from Gas	99+ ³	N.A.	100	<0.25	<0.25
3P		Particulate	Solids from Gas	N.A.	N.A.	3.0	0.25	N.A.
A		Adsorber	Vapor from Gas	99+ ⁴	N.A.	3.0	1.0	N.A.

¹Tested per ISO 12500-1 at 40 ppm inlet.

²Add dry + wet columns for total pressure drop.

³Bulk liquid removal efficiency..

⁴Oil vapor removal efficiency is given for A media.

Applications:

High Pressure (HP) Filter Applications

Test Air for HP Hydraulics	10C / 7CP				
Inter-stage HP Compressor	WS / 10C				
CNG Compressor Outlet	10C	→	4C		
CNG Storage Cascades	10C	→	4C		
CNG Dispensers	10C	→	4C		
Breathing Air / SCUBA	10C	→	4C	→	A
High Pressure "Ultra Pure Air"	10C	→	4C	→	4C → A
Bulk Liquid contamination	WS	→	7CP	→	4C
Bulk solid Contamination	3P	→	7CP	→	4C
HP Air / Gas Dryer Protection	10C / 7CP	→	4C	→	Dryer → 7CP / 3P
Food Applications / Odor Removal	10C / 7CP	→	4C	→	A



Flow Rates:

Choose Filter Size to find the corresponding flow rates

J-Series Flow Rates (SCFM)												
Model	Port	Filter Type	100 PSIG	1000 PSIG	1500 PSIG	2000 PSIG	2500 PSIG	3000 PSIG	3500 PSIG	4000 PSIG	4500 PSIG	5000 PSIG
J_1A	1/4"	4C, A	15	135	200	265	330	395	460	525	590	655
		7CP, 10C, 3P, WS	30	265	395	525	660	790	920	1050	1180	1310
J_2A	1/2"	4C, A	25	220	330	440	550	655	765	875	985	1095
		7CP, 10C, 3P, WS	50	440	660	880	1095	1315	1530	1750	1970	2185
J_2B	1/2"	4C, A	35	310	460	615	765	920	1070	1225	1380	1530
		7CP, 10C, 3P, WS	80	710	1055	1405	1755	2105	2450	2800	3150	3500
J_3B	3/4"	4C, A	60	530	790	1055	1315	1575	1840	2100	2360	2525
		7CP, 10C, 3P, WS	130	1150	1715	2285	2850	3415	3985	4550	5115	5685
J_4C	1"	4C, A	90	795	1190	1580	1975	2365	2760	3150	3540	3935
		7CP, 10C, 3P, WS	200	1770	2640	3515	4385	5255	6130	7000	7870	8745
J_6D	1-1/2"	4C, A	180	1590	2375	3160	3945	4730	5515	6300	7085	7870
		7CP, 10C, 3P, WS	400	3540	5280	7025	8770	10515	12255	14000	15745	17490
J_8E	2"	4C, A	275	2435	3630	4830	6030	7230	8425	9625	10825	12025
		7CP, 10C, 3P, WS	600	5310	7925	10540	13155	15770	18385	21000	23615	26230

Note: These rates are based on compressed air flow. For CNG, these flows can be multiplied by a factor of 1.2.

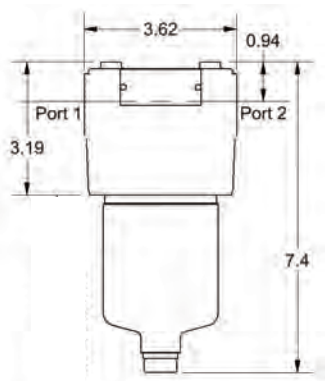

J_A Series

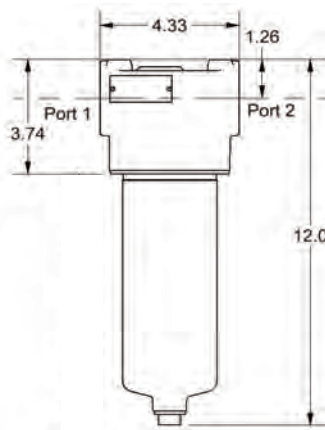

J_B Series

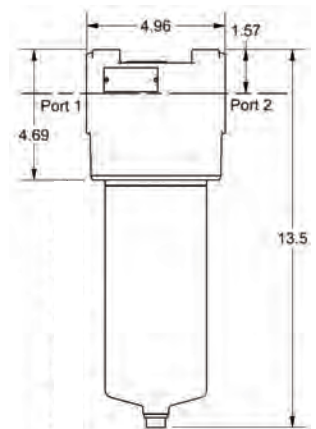

J_C Series

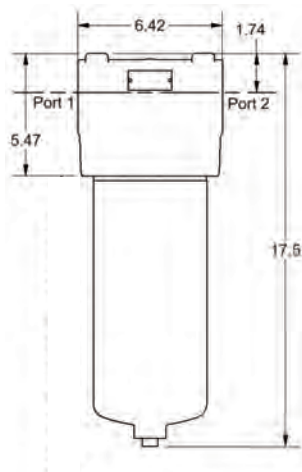

J_D Series

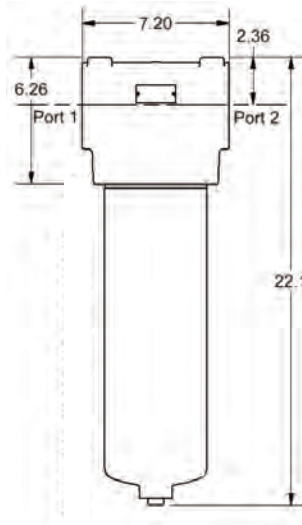

J_E Series

Specifications:

Model	J_1A	J_2A	J_2B	J_3B	J_4C	J_6D	J_8E
Port Size (N=NPT)	1/4" NPT	1/2" NPT	1/2" NPT	3/4" NPT	1" NPT	1-1/2" NPT	2" NPT
Port Size (S=SAE)	SAE-4	SAE-8	SAE-8	SAE-12	SAE-16	SAE-24	SAE-32
Max. Pressure	5000 PSIG	5000 PSIG	5000 PSIG	5000 PSIG	5000 PSIG	5000 PSIG	5000 PSIG
Max. Temperature¹	350°F	350°F	350°F	350°F	350°F	350°F	350°F
Head	SG Iron*	SG Iron*	SG Iron*	SG Iron*	SG Iron*	SG Iron*	SG Iron*
Bowl	Steel	Steel	Steel	Steel	Steel	Steel	Steel
Seals:	Fluorocarbon	Fluorocarbon	Fluorocarbon	Fluorocarbon	Fluorocarbon	Fluorocarbon	Fluorocarbon
Backing Ring	Nitrile	Nitrile	Nitrile	Nitrile	Nitrile	Nitrile	Nitrile
Sump Volume	50 mL	50 mL	180 mL	180 mL	230 mL	500 mL	500 mL
Weight	9.0 lbs.	9.0 lbs.	13.0 lbs.	13.0 lbs.	21.0 lbs.	45.0 lbs.	67.0 lbs.
Port to Port	3.62"	3.62"	4.33"	4.33"	4.96"	6.42"	7.2"
Height	7.4"	7.4"	12.0"	12.0"	13.5"	17.5"	22.1"
Clearance	2.0"	2.0"	2.25"	2.25"	2.25"	3.0"	3.0"
Drain Port	SAE-6	SAE-6	SAE-6	SAE-6	SAE-6	SAE-6	SAE-6
Socket / Bowl Removal	1-1/16" HEX	1-1/16" HEX	1-1/16" HEX	1-1/16" HEX	1-1/16" HEX	1-1/2" HEX	1-1/2" HEX
Head / Bowl Torque	15-20 ft.-lbs.	15-20 ft.-lbs.	25-30 ft.-lbs.	25-30 ft.-lbs.	25-30 ft.-lbs.	60-70 ft.-lbs.	60-70 ft.-lbs.

*Note: SG Iron is an abbreviation for Spheroidal Graphite Cast Iron

High Pressure Drains and Gauge:

JDK5000H	Horizontal Drain Kit 5000 psig
JDK5000V	Vertical Drain Kit 5000 psig
BDPI-25	Differential Pressure Gauge and Bracket

Note: Replacement Element supplied with o-ring and lube tube.

How To Order

Part Numbers for Complete Assemblies:

Use the steps below to build your own part number.

For any permutation not mentioned below, please consult factory at 1-800-521-4357.

<input type="text"/>	<input type="text"/>	<input type="text"/>	=	<input type="text"/>	-	<input type="text"/>	<input type="text"/>
Series Name	Thread	Port Size	=	Housing Size		Media Grade	Accessories
J	N - NPT	1 (1/4")	=	A		4C	N = None
	S - SAE	2 (1/2")	=	A		10C	Available
		2 (1/2")	=	B		7CP	
		3 (3/4")	=	B		WS	
		4 (1")	=	C		3P	
		6 (1-1/2")	=	D		A	
		8 (2")	=	E			

Examples:

JN2A-4CN, JS6D-WSN, JN3B-3PN

Replacement Element Part Numbers:

Note: Replacement element supplied with replacement head/bowl seals and tube of lubricant.

<input type="text"/>	<input type="text"/>	<input type="text"/>	<input type="text"/>
Media Grade/Type	Series Name	Housing Size	Kit
4C	J	A	K
10C		B	
7CP		C	
WS		D	
3P		E	
A			

Examples:

4CJAK, WSJDK, 3PJBK



J-Series filters are used in a number of applications, ranging from breathing air for scuba divers, to high-pressure hydraulic circuit testing, to a variety of uses in the alternative fuel industry.

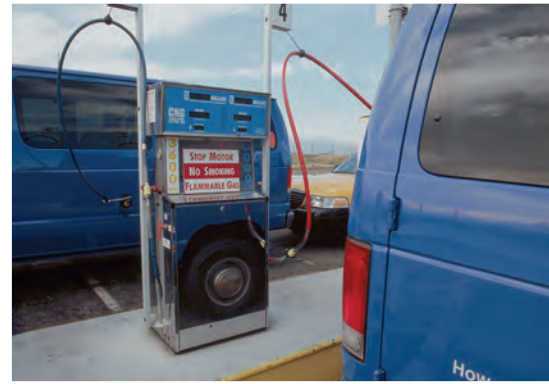

Worldwide Filtration Manufacturing Locations

North America

Compressed Air Treatment Filtration & Separation/Balston

Haverhill, MA
978 858 0505
www.parker.com/balston

Finite Airtek Filtration Airtek/domnick hunter/Zander

Lancaster, NY
716 686 6400
www.parker.com/faf

Finite Airtek Filtration/Finite

Oxford, MI
248 628 6400
www.parker.com/finitefilter

Engine Filtration & Water Purification Racor

Modesto, CA
209 521 7860
www.parker.com/racor

Holly Springs, MS
662 252 2656
www.parker.com/racor

Beaufort, SC
843 846 3200
www.parker.com/racor

Racor – Village Marine Tec.

Gardena, CA
310 516 9911
desalination.parker.com

Parker Sea Recovery

Carson, CA
310 637 3400
www.searecovery.com

Hydraulic Filtration Hydraulic Filter

Metamora, OH
419 644 4311
www.parker.com/hydraulicfilter

Laval, QC Canada
450 629 9594
www.parkerfarr.com

Process Filtration domnick hunter Process Filtration

Oxnard, CA
805 604 3400
www.parker.com/processfiltration

Madison, WI
608 824 0500
www.scilog.com

Phoenixville, PA
610 933 1600
www.parker.com/processfiltration

Aerospace Filtration

Velcon Filtration
Colorado Springs, CO
719 531 5855
www.velcon.com

Europe

Compressed Air Treatment domnick hunter Filtration & Separation

Gateshead, England
+44 (0) 191 402 9000
www.parker.com/dhfn

Parker Gas Separations

Etten-Leur, Netherlands
+31 76 508 5300
www.parker.com/dhfn

Hiross Zander

Padova Business Unit
Padova, Italy
+39 049 9712 111
www.parker.com/hzd

Hiross Zander

Essen Business Unit
Essen, Germany
+49 2054 9340
www.parker.com/hzd

Engine Filtration & Water Purification Racor

Dewsbury, England
+44 (0) 1924 487 000
www.parker.com/rfde

Racor Research & Development

Stuttgart, Germany
+49 (0)711 7071 290-10
www.parker.com/rfde

Hydraulic Filtration Hydraulic Filter

Arnhem, Holland
+31 26 3760376
www.parker.com/hfde

Urjala Operation

Urjala, Finland
+358 20 753 2500
www.parker.com/hfde

Condition Monitoring Centre

Norfolk, England
+44 (0) 1842 763 299
www.parker.com/hfde

Parker Kittiwake

West Sussex, England
+44 (0) 1903 731 470
www.kittiwake.com

Parker Procal

Peterborough, England
+44 (0) 1733 232 495
www.kittiwake.com

Process Filtration domnick hunter Process Filtration

Birtley, England
+44 (0) 191 410 5121
www.parker.com/processfiltration

Parker Twin Filter BV

Zaandam, Netherlands
+31(0)75 655 50 00
www.twinfilter.com

Asia Pacific

Australia

Castle Hill, Australia
+61 2 9634 7777
www.parker.com/australia

China

Shanghai, China
+86 21 5031 2525
www.parker.com/china

India

Navi Mumbai, India
+91 22 651 370 8185
www.parker.com/india

Parker Fowler

Bangalore, India
+91 80 2783 6794
www.johnfowlerindia.com

Japan

Tokyo, Japan
+81 45 870 1522
www.parker.com/japan

Parker Techno

Osaka, Japan
+81 66 340 1600
www.techno.taiyo-ltd.co.jp

Korea

Hwaseon-City
+82 31 359 0852
www.parker.com/korea

Singapore

Jurong Town, Singapore
+65 6887 6300
www.parker.com/singapore

Thailand

Bangkok, Thailand
+66 2186 7000
www.parker.com/thailand

Latin America

Parker Comercio Ltda. Filtration Division

Sao Paulo, Brazil
+55 12 4009 3500
www.parker.com/br

Pan American Division

Miami, FL
305 470 8800
www.parker.com/panam

Africa

Aeroporto Kempton Park, South Africa
+27 11 9610700
www.parker.com/africa



Parker Hannifin Corporation
Finite Airtek Filtration Division
500 S. Glaspie Street
Oxford, MI 48371
phone 248 628 6400
fax 248 628 1850
www.parker.com/finitefilter

